

VB Series Vacuum Power Unit



Process Control specializes in equipment for bulk conveying of plastic materials. Our conveying equipment is designed to stand up to the demands of your application.

To prevent bottle-necking and ensure a continuous supply to the material's destination, Process Control engineers work with you to select the best equipment and integrate it into a reliable system capable of continuous operation and guaranteed performance.

The VB Series from Process Control is designed for low to moderate rate conveying and quiet, low-maintenance performance. As part of an integrated material handling system, the VB Series can improve the efficiency of your plastics processing.

Standard Features

- ◆ 3, 6.2, and 7.5 HP
- ◆ Quiet ring compressor design
- ◆ TEFC Motor (indoors only)
- ◆ Duel stage intake filter
- ◆ Vacuum relief valve
- ◆ Power: 460V/3PH/60HZ
- ◆ Control Voltage: 24VDC or 115VAC
- ◆ Motor starter panel

Options

- ◆ Variable Speed Drive controlled
- ◆ Special voltages
- ◆ Continuous run valve to reduce pump cycling



PROCESS CONTROL CORPORATION

World Headquarters
6875 Mimms Drive, Atlanta, GA 30340 USA
Ph 770.449.8810 Fax 770.449.5445

Process Control GmbH
Birstein, Germany
Ph +19-6051-91 29-0 Fax +19-6051-91 29-99

VB Series Vacuum Power Unit

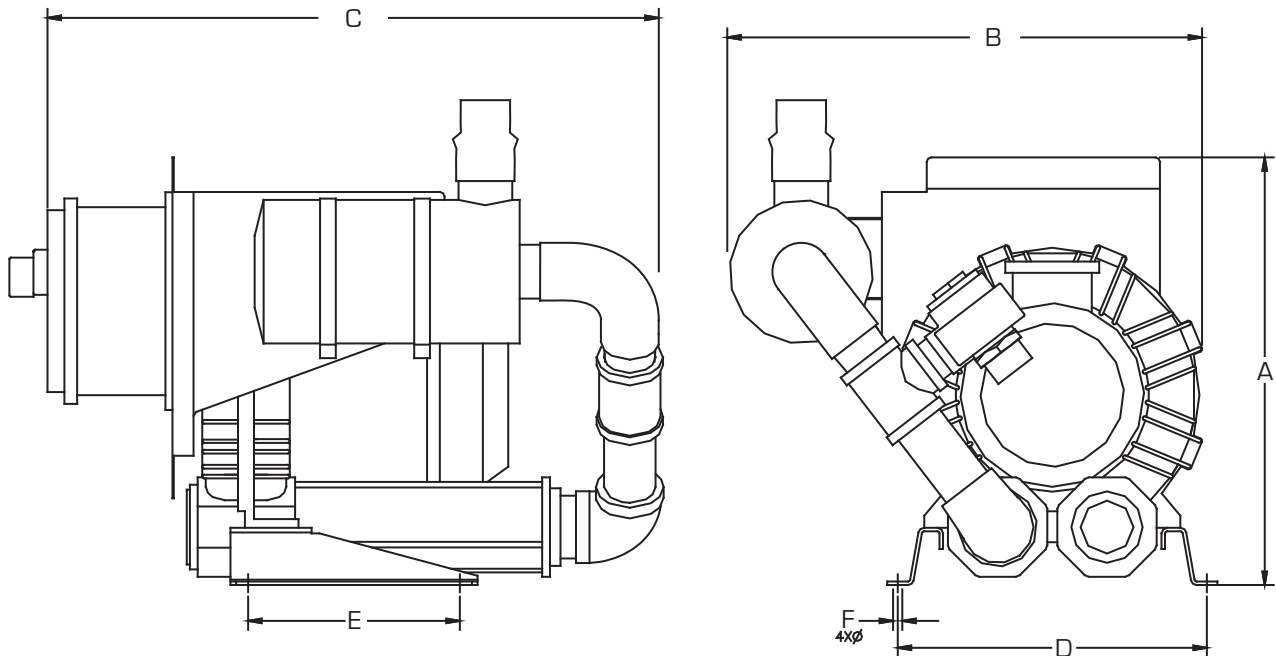

Specifications for VB Series Vacuum Power Unit

Model Number	Power HP (kW)	Tube Size in (mm)	A in (mm)	B in (mm)	C in (mm)	D in (mm)	E in (mm)	F in (mm)	Shipping Weight lbs (kg)
VBB	3 (2.2)	2.0 (51)	23.1 (587)	21.3 (542)	25.6 (651)	10.24 (260)	4.53 (115)	0.550 (14)	100 (45)
VBC	6.2 (4.5)	2.0 (51)	20.0 (509)	24.1 (611)	24.7 (627)	11.42 (290)	5.51 (140)	0.600 (15.2)	150 (54)
VBD	7.5 (5.6)	2.5 (64)	23.8 (605)	26.5 (673)	34.0 (866)	17.24 (438)	11.81 (300)	0.512 (13)	200 (91)

Accessories



Surge Hopper



Vacuum Receivers



Pneumatic Tilter



Director Sequencing Panel



Dust Collector