

# 12kg Guardian® Series 2 Blender Optional Accessories

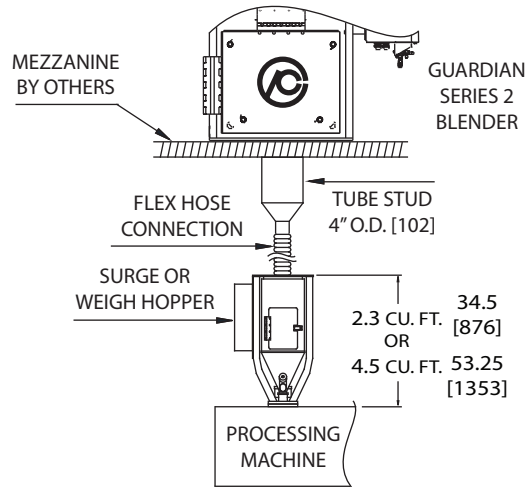
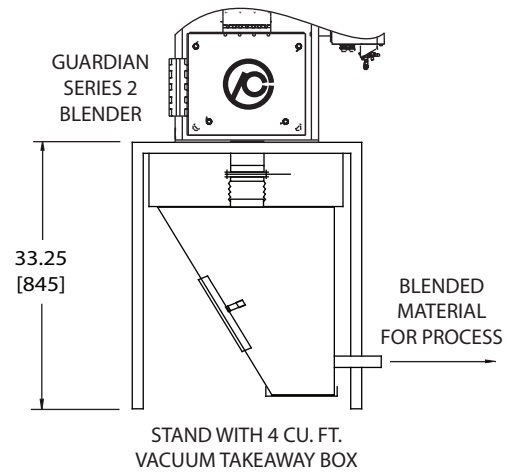
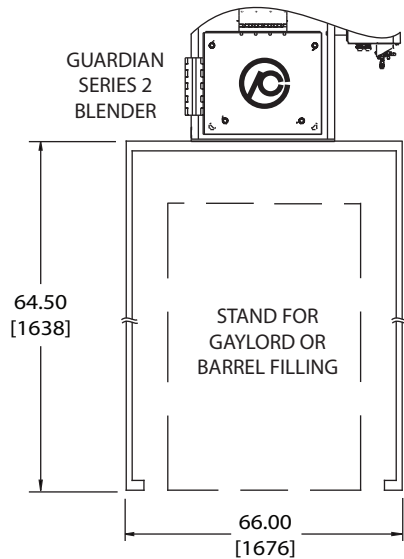

[ ] dimensions are in mm

## Optional Features

- Dispensing gate restrictor plate for very low rate ingredients
- Integral extruder and linespeed control modules for mono-extrusion
- Extended cables for remote mounting touch-screen operator control panel
- Low level proximity sensor for material hoppers
- Drain with butterfly valve for material hoppers
- Regrind or Powder Feeder Elements
- Special Electricals
- Special Paint
- Blend Manager software
- Self-Loading Controls
- Up to 12 elements for 12kg
- For higher throughputs, see specification sheet for 18kg and 25kg Guardian® Series 2 Gravimetric Blenders