

RP Series

Vacuum Receiver for Dusty Material



When used in conjunction with PCC's Vacuum Power Units, the RP Series provides processors with dependable and efficient conveying of dusty materials (pictured is an RPG)

The RP Series Vacuum Receiver from Process Control is part of a complete vacuum conveying system for in-plant distribution or machine/blender loading. When coupled with a vacuum pump and sequencing panel, the RP Series provides automatic loading of materials.

The RP's design accomplishes cleaning with conveying air. No plant compressed air is used for cleaning. The receiver's self-cleaning action is achieved by controlled timing of the sequencing vacuum valves. At the start of the cycle, air is drawn back-

ward through one set of filter bags, dislodging any fines and dropping them back into the hopper. After filling, the second set of filters is back-flushed. Finally, both filters are opened; the resin is delivered to its destination.

The RP Series avoids carry-over of dust back to the vacuum power unit. The filter bags in the RP Series feature large filter areas to promote low, stable pressure drop.

The RP Series Vacuum Receiver is low-maintenance. No valves come

into contact with conveyed material and no tools are needed for filter cleaning or changes.

Multiple station capability is engineered into the RP Series design, allowing use of vacuum valves. PCC's RP Series is easily retrofitted to conform to your existing standard vacuum system. An optional modular control box operates valves from the existing sequencing fill signal to minimize field wiring. ■

Standard Features

- Air operated sequencing valve in lid requires 80-100 psi of filtered, lubricated shop air for solenoid actuators and control cylinders. The total supply air required per cycle is 0.01 cu.ft.
- Internal self-cleaning filter bags for granular or dusty materials
- 24 VDC control voltage
- Flapper-type discharge valve with magnetic switch
- Removable lid with V-band clamp
- Mild steel construction

Options

- Check valve for common material line applications
- Swing-gate or knife-gate positive shut-off discharge valve
- 110VAC control voltage
- Stainless steel construction
- Load level proximity switch
- Pre-wired junction box to simplify installation
- High temperature design

RP Series Vacuum Receiver for Dusty Material

With Flapper Valve Discharge

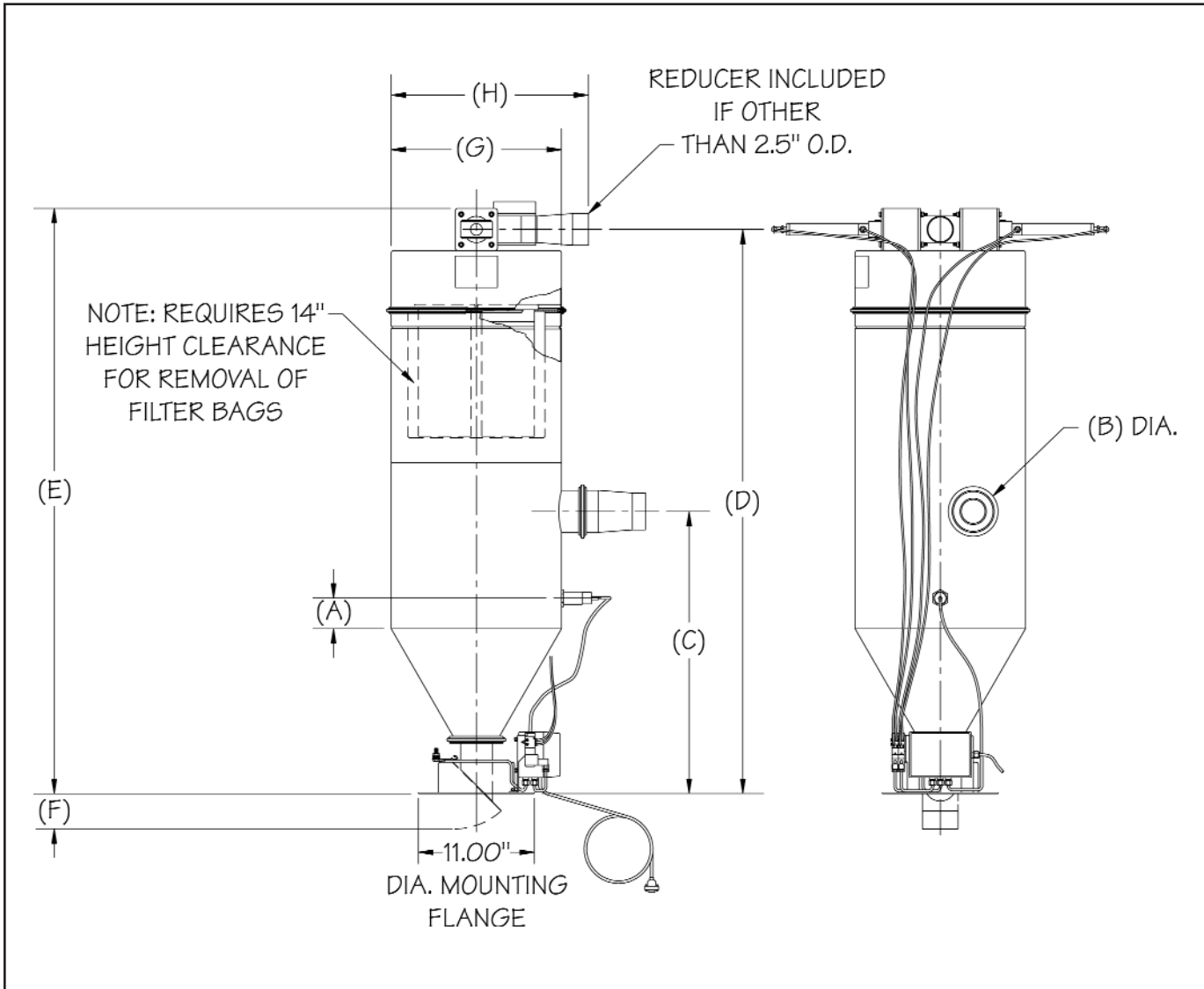

SPECIFICATIONS for RP SERIES VACUUM RECEIVER with FLAPPER VALVE DISCHARGE

Model Number	Working Capacity cu.ft. (dm ³)	Dimensions - Inches (mm)								Shipping Weight Lbs (kg)
		A	B	C	D	E	F	G	H	
RPF	.40 (11.3)	2.5 (63)	2.0 (51)	19.9 (505)	40.5 (1028)	42.5 (1079)	3.3 (85)	12.0 (305)	15.6 (395)	150 (68)
			2.5 (64)							
RPG	.54 (15.3)	4.19 (106)	3.0 (76)	24.0 (608)	50.7 (1287)	52.7 (1337)	8.2 (208)	16.0 (406)	17.6 (446)	200 (91)
			3.5 (89)							
RPH	.88 (24.9)	2.88 (73)	2.0 (51)	39.0 (989)	63.8 (1620)	65.8 (1671)	8.2 (208)	16.0 (406)	17.6 (446)	250 (114)
RPJ	1.44 (40.8)	7.63 (194)	2.5 (64)							
RPK	2.58 (73.0)	17.50 (445)	1.5 (38)	39.0 (989)	63.8 (1620)	65.8 (1671)	8.2 (208)	16.0 (406)	17.6 (446)	250 (114)
RPL	3.14 (88.9)	22.25 (565)	2.0 (51)							
			2.5 (64)							
			3.0 (76)							
			3.5 (89)							
			4.0 (102)							

RP Series Vacuum Receiver for Dusty Material

With Swing-gate Valve Discharge

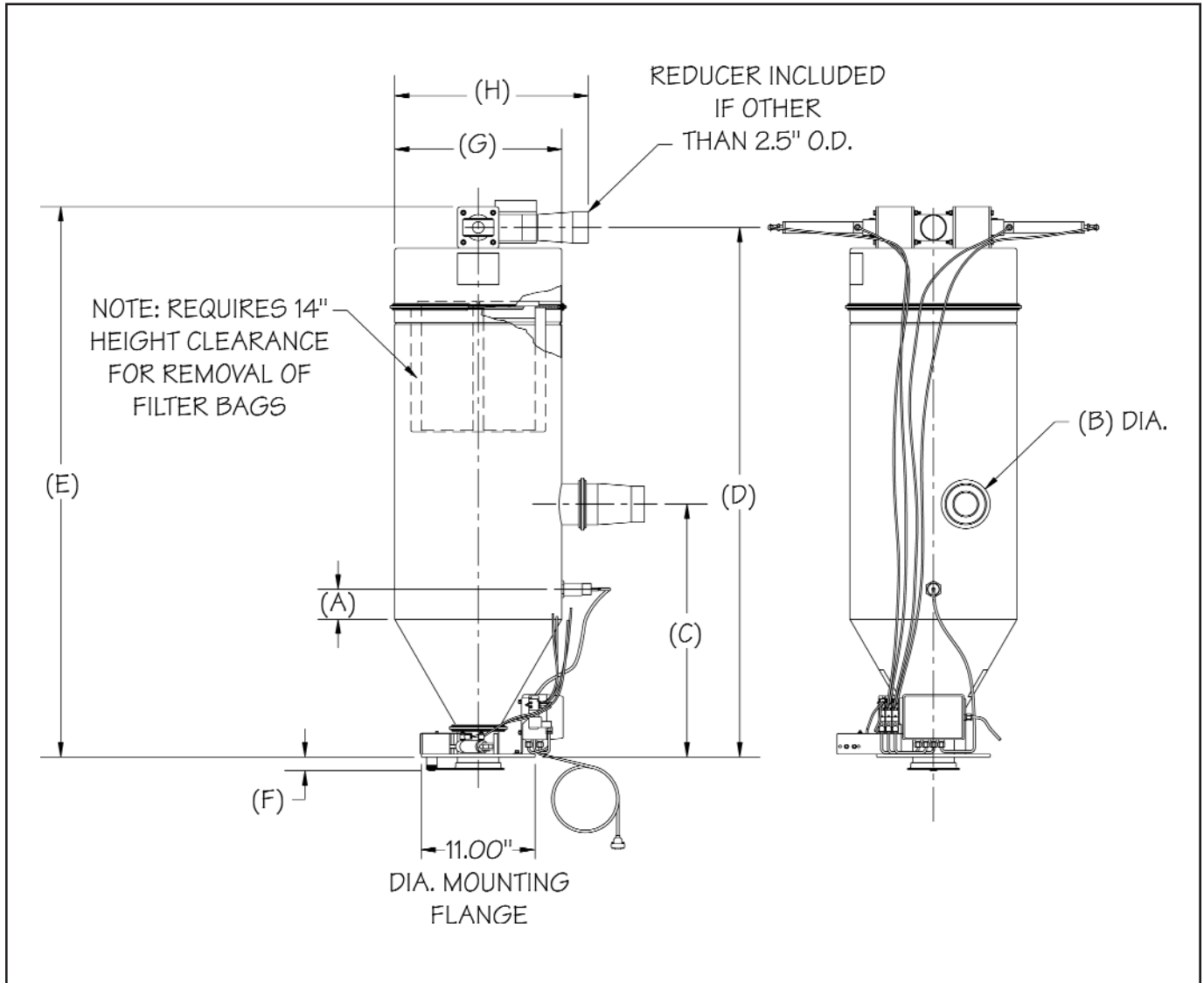

SPECIFICATIONS for RP SERIES VACUUM RECEIVER with SWING GATE VALVE DISCHARGE

Model Number	Working Capacity cu.ft. (dm ³)	Dimensions - Inches (mm)								Shipping Weight Lbs (kg)
		A	B	C	D	E	F	G	H	
RPF	.40 (11.3)	2.5 (63)	2.0 (51)	17.6 (446)	38.1 (968)	42.5 (1079)	1.4 (34.2)	12.0 (305)	15.6 (395)	150 (68)
			2.5 (64)							
RPG	.54 (15.3)	4.2 (106)	3.0 (76)	24.4 (620)	51.1 (1298)	52.7 (1337)	16.0 (406)	17.6 (446)	200 (91)	
			3.5 (89)							
RPH	.88 (24.9)	2.9 (73)	2.0 (51)	39.4 (1001)	64.2 (1632)	66.2 (1682)	17.6 (446)	250 (114)		
RPJ	1.44 (40.8)	7.6 (194)	2.5 (64)							
			3.0 (76)							
RPK	2.58 (73.0)	17.5 (445)	3.5 (89)	39.4 (1001)	64.2 (1632)	66.2 (1682)	17.6 (446)	250 (114)		
			4.0 (102)							
RPL	3.14 (88.9)	22.3 (565)	1.5 (38)	39.4 (1001)	64.2 (1632)	66.2 (1682)	17.6 (446)	250 (114)		
			2.0 (51)							
RPL	3.14 (88.9)	22.3 (565)	2.5 (64)	39.4 (1001)	64.2 (1632)	66.2 (1682)	17.6 (446)	250 (114)		
			3.0 (76)							
RPL	3.14 (88.9)	22.3 (565)	3.5 (89)	39.4 (1001)	64.2 (1632)	66.2 (1682)	17.6 (446)	250 (114)		
			4.0 (102)							

RP Series Vacuum Receiver for Dusty Material

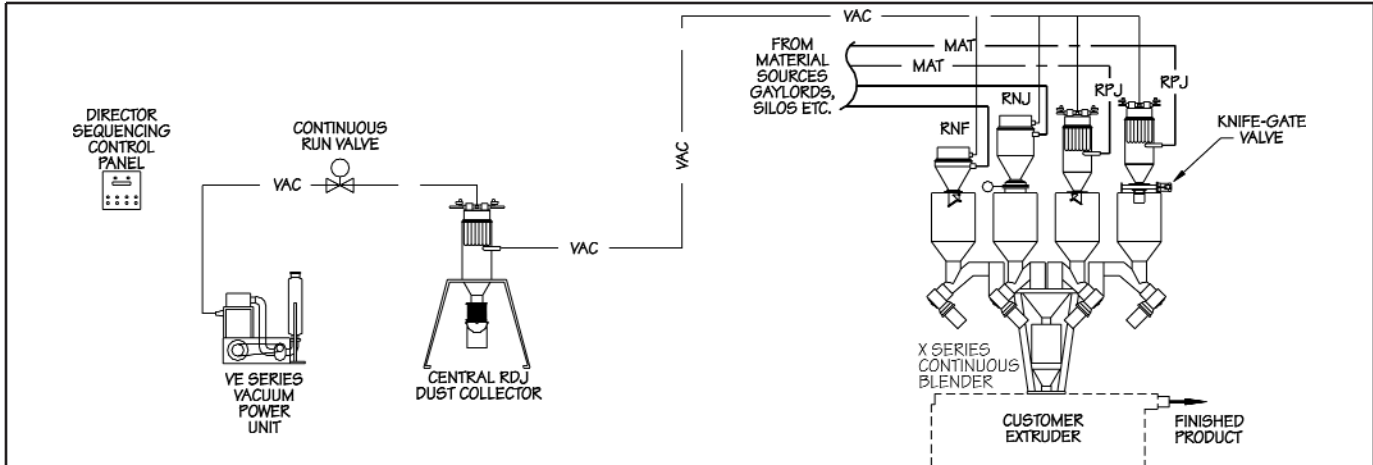

* Schematic above depicts typical Gravimetric Blending Loading System.

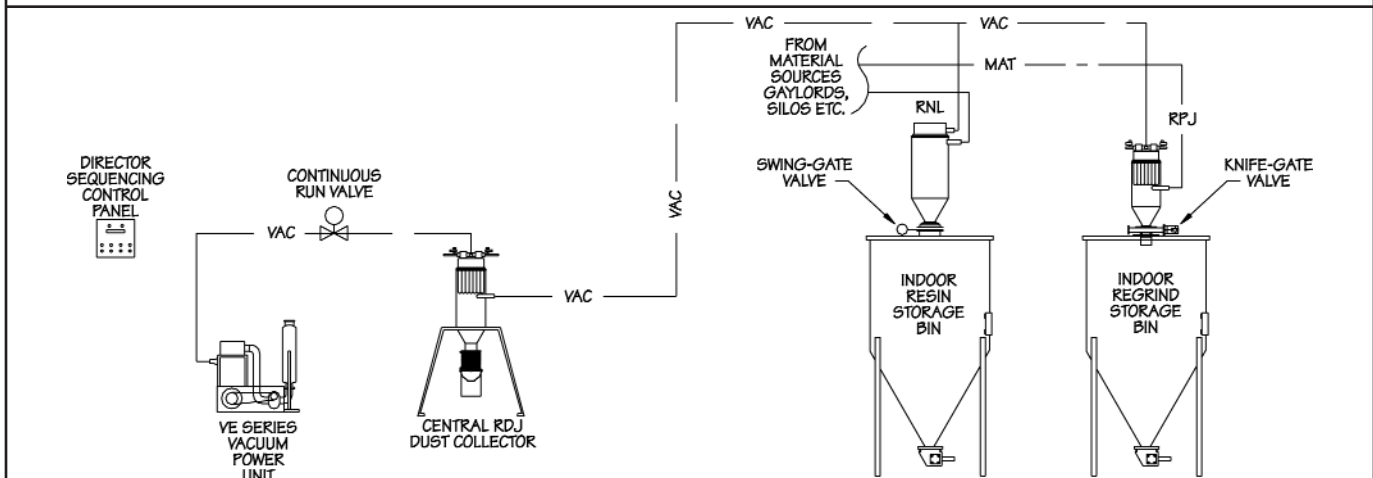

* Schematic above depicts typical In-plant material Storage Bin Loading System.

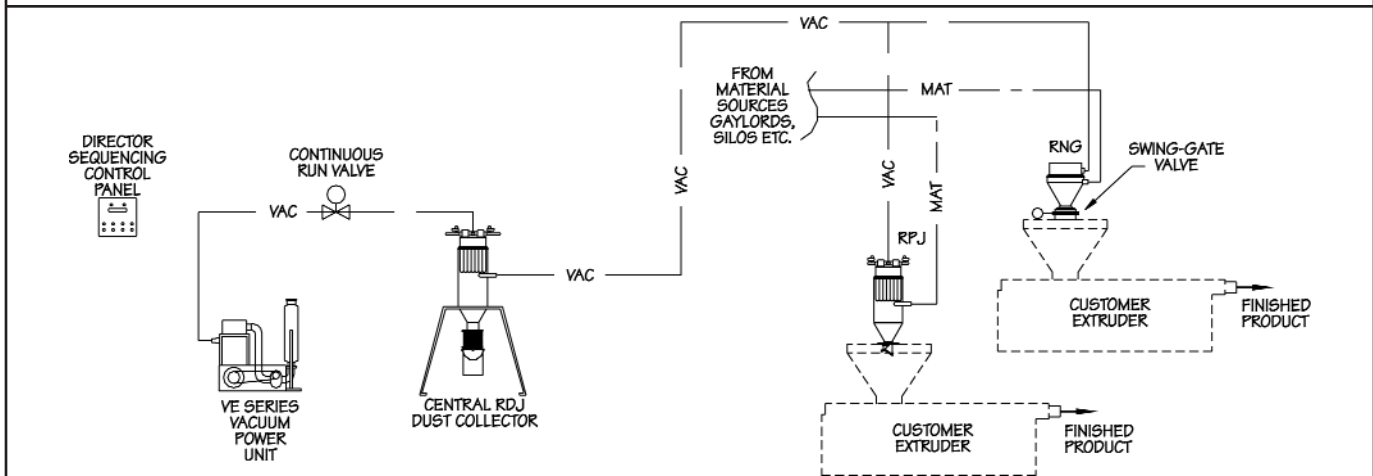

* Schematic above depicts typical Extruder Loading System.



PROCESS CONTROL Corporation
World Headquarters
 6875 Mimms Drive, Atlanta, GA 30340 USA
 Tel: (770) 449-8810 Fax: (770) 449-5445
 www.process-control.com

Process Control China Limited
 Guangzhou, Guangdong Province, China
 TEL: +8620 28395688 FAX: +8620 28395773

Process Control GmbH
 Birstein, Germany
 TEL: +49-6054-91 29-0 FAX: +49-6054-91 29-99